

# Smart Electronic System for Women Safety

S Shambhavi<sup>1</sup>, M Nagaraja<sup>1</sup>, M.Z Kurian<sup>1</sup>

Department of Electronics and Communication, Sri Siddhartha Institute of Technology, Tumakuru, India<sup>1</sup>

**Abstract:** This paper describes about a safety electronic system for women, built in public transport vehicles such as cars, buses and auto-rickshaws as nowadays women are being molested, kidnapped and harassed by the drivers. Hence implemented electronic system is fitted in the vehicle which has display, keypad, GPS, GSM and embedded board to control and interconnect all of the above. As journey is started passenger can enter her guardian, friend or relative mobile no, he/she is going to get all the notifications of the female passenger journey. First of all the driver's name, mobile number, vehicle registration number and the secure pin generated by passenger is sent by SMS to the concern person of passenger. We can also add destination region even though if the concerned person does not check the updates, then also it would be useful in investigation, if any mishappening occurs. Passenger may always not get down at destination decided, she may get down little early or little further depending on various factors, hence an option to terminate journey is also provided called as end of journey which is executed and validated using secure pin, which driver will not be aware of. This system uses serial EEPROM to store various locations of cities and hence new locations can be added and thus project will work in any city because locations are not hardcoded in the code but it is external to code.

**Keywords:** Safety System, GPS, GSM, Embedded System.

## 1. INTRODUCTION

India is a country of peace-loving and law-abiding citizens. It is a safe destination for domestic and international tourists. However, like any other civil society, there are aberrations, and a few persons break the law now and then. In recent past, a few isolated incidents have been reported in India in which women travellers were sexually assaulted. There have been many cases where cab drivers, taxi drivers or auto rickshaw drivers have harassed, molested or tried to kidnap the women passengers. Many women are afraid to be alone in public places due to fear of being harmed. This fear has been caused by repeated cases of violence towards women. Women's empowerment in the country can be brought once their safety and security is ensure, either it may be at home, publics places or during travelling.

Many attempts are made to make women journey safer [1-6]. This paper presents design and implementation of women safety system which will ensure women safety during travelling (as shown in below figure-1) in public transport vehicles such as cabs, taxi, bus and auto rickshaw.

## 2. EXISTING PROBLEM

- Women are the subject of exploitation inside and outside the home say whether on roads, trains, cabs, schools etc.
- Women occupy almost half the globe. But their survival has always been a question, when it comes to existence with honour and dignity.
- Women's empowerment in the country can be brought once their safety and security is ensure, either it may be at home, publics places or during travelling.

### Solution to the problem:

The level of security can be increased more by electronics assistance device in the vehicle, which can track the journey or women passenger, and ensure she has

completed journey without any problems, this will not only make them safe but their parents, kids or husbands will also feel stress free as they are virtually in touch during complete journey.

## 3. SYSTEM DESIGN AND MPLEMENTATION

### Blocks Description:

Embedded board is the main system which controls and connects to all other modules in the project, this module will contain a microcontroller and microcontroller related circuit which is use to run it and interface to it.

4x4 Keypad is used to enter relatives/friend mobile no who get your location updates, start of journey notification along with driver details and end of journey notification, secure pin also will be sent to this mobile no. Same keypad functions can be extended to use this for entering text for destination location.

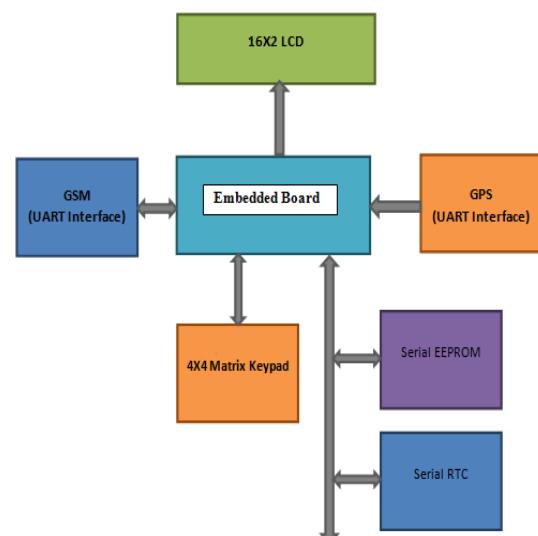
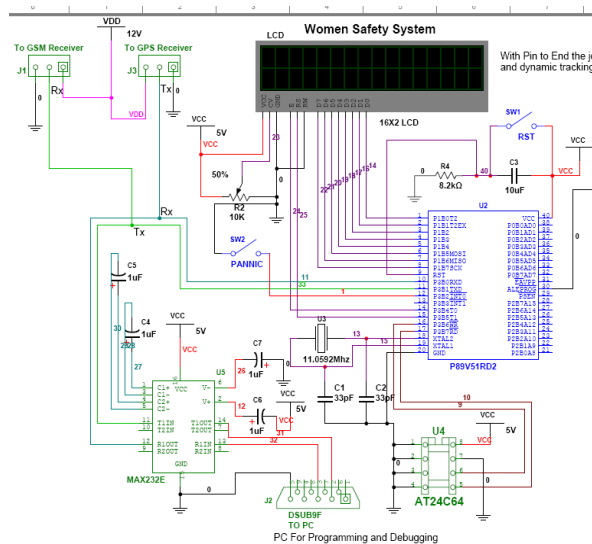

**Fig1:** Block Diagram of the Women Safety System

LCD is used to display driver and vehicle details, other interface related messages. GPS is used to get the location of the vehicle at any given point of time, it is interface to microcontroller using a UART link and output of the GPS is read by the program running in main embedded board. GSM is interfaced to the microcontroller unit (MCU) using a UART link and AT commands are used to interface gsm and operate it, sms are sent using this device. Serial EEPROM is I2C based EEPROM only two wires are required i.e. DATA and clock for interfacing it with the MCU instead of many data line, address line and control in traditional EEPROM chip. Similar interface is used with RTC chip this chips keeps track of date and time.

### 3.2 SYSTEM IMPLEMENTATION P89V51RD2:

Implementation of women safety system is as shown in figure-2. The first major component of the system is the microcontroller. The P89V51RB2/RC2/RD2 are 80C51 microcontrollers with 16/32/64 kB flash and 1024 B of data RAM. A key feature of the P89V51RB2/RC2/RD2 is its X2 mode option. In this project we can choose to run the application with the conventional 80C51 clock rate (12 clocks per machine cycle) or select the X2 mode (six clocks per machine cycle) to achieve twice the throughput at the same clock frequency. Another way to benefit from this feature is to keep the same performance by reducing the clock frequency by half, thus dramatically reducing the EMI. The different codes that we used to run this project are embedded and dumped into this microcontroller as the location varies when the device is used in different cities; hence it is external to the code.



**Fig2: System Implementation**

#### LCD:

16 X 2 lines LCD is an industry standard liquid crystal display (LCD) display device designed for interfacing with embedded systems. LCDs use a standard 14-pin interface and those with backlights have 16 pins. The LCD is used in our project to display the messages of the driver's details, vehicle no details as well as the secured pin used to start and end the journey.

#### Algorithm to send data to LCD:

1. Make R/W low
2. Make
  - RS=0 ;if data byte is command
  - RS=0 ;if data byte is command
  - RS=1 ;if data byte data (ASCII value to displayed LCD)
3. Place data byte on data bus
4. Pulse E (HIGH to LOW)
5. Check BF or give some safe delay
6. Repeat the steps to send another data byte

#### GPS:

In our women safety system the GPS acts as a receiver as it takes the signal from the satellite and works as shown below:

#### Working of GPS:

The GPS receiver is used to get accurate geographical location by receiving information from satellites. It receives information from satellites and gives location information in terms of latitude and longitude. It gives latitude and longitudes with accuracy of degree-minute-second. Using this latitude and longitude co-ordinates one can easily trace out the location of the vehicle and track the position of passenger in case of any mishappening.

#### GSM:

The GSM system is the most widely used cellular technology in use in the world today. It has been a particularly successful in cellular phone technology for its various features. In this Implemented women safety system, interfacing of the AT89C51 microcontroller with the GSM module and the HyperTerminal has been done. HyperTerminal is a Windows application. The AT commands are sent by the HyperTerminal to the GSM module. The Information Response and/or Result Codes are received at the microcontroller and retransmitted to the HyperTerminal by the controller.

### 4. CONCLUSION

In this work implementation smart electronic system has been implanted using microcontroller, GPS, GSM etc. This electronic security system can be used as a tracking device to ensure women safety during travelling in various public transport vehicles such as cabs, taxi, auto rickshaw etc.

### REFERENCES

- [1] R. George, A. Cherian., A. Antony, H. Sebastian, M. Antony, B.T.Rosemary An Intelligent Security System for Violence against Women in Public Places, International Journal of Engineering and Advanced Technology (IJIEAT) ISSN: 2249 – 8958, Volume-3, Issue-4, April 2014.
- [2] S. Sangeetha, P. Radhika, Application for Women Safety, IOSR Journal of Computer Engineering (IOSR-JCE), Volume 17, Issue 3, Ver. IV (May – Jun. 2015), PP 01-04.
- [3] E. Peter, Andrew, and B Paul, S. Matt, H. Jason, P. Carlos, and M Scarlett. Designing Public Safety Mobile Applications for Disconnected, Interrupted and Low Bandwidth Communication Environments. IEEE. 10 (978-1-4799-1535-4/13), p790-796(2013).
- [4] A mobile application for women"-Times of India, Dec 03 2013.
- [5] Electronic Device for Women Safety"- Times of India, Sep 15 2013.
- [6] Y. Tian, T. Kanade and J. Cohn, Recognizing Action Units for Facial Expression Analysis, IEEE Trans. Pattern Analysis and Machine Intelligence ,vol. 23, no. 2, pp. 97–115, 2001.